

ARCHITECTURAL DESIGN I REPORT

# ARCHITECTURAL DESIGN I REPORT

Lecturer: Dr. Henriette Bier

CAD Instructor: Max Latour

Student ID: 16759

Nguyen Vu Minh Thu

Vietnamese German University

## **Introduction**

This form is a “wall” that divides a 2,000-square-foot loft space into two distinct spaces of an office furniture company. One space is the reception and lounge space (order entry) where the company can meet their client, the other serves as a design studio.

Originally designed on the idea of Denari Project (*Denari Project*, n.d.), this separator works as an indoor pavilion that drew inspiration from folded origami maquettes. Since the levels of stress and depression in the workplace are increasing, the objective of the form is creating a space where employees can relax, interact with their colleagues, boost their productivity and creativity at work. Besides, the project aims to solve the problem of the previous design in visual privacy and the rough path of the staircase in the Denari.

## **Methodology**

### **Studying the precedent**

Based on Denari's design, problems were identified to create a suitable alternative. The void space at the frame structure and the staircase leading to the floor were the two discomforts that were determined. Therefore, a new project was started with the idea of having a separator that protects the design studio from unwanted glare and provides a smooth path rather than a leveling floor with stairs connecting between the two spaces.

### **Establishing requirements**

Previous research and statistics have pointed out that stress and depression are among the most common issues in the workplace (Ashkanasy et al., 2003). Moreover, the lack of greenery in buildings was also considered a serious today's issue. Therefore, this project will be a human-

## ARCHITECTURAL DESIGN I REPORT

centric space. When people have a quality experience in a space, they are more engaged.

Engagement translates into more productive workers, more customers and more social shares of well-designed spaces.

### **Framing functions:**

The form is mainly designed for employee's experience and would be mostly utilized by these occupants, however, customer's needs have also been taken into consideration during the schematic design process. Thus, this design focuses on building a relaxing space in the common walkway where separator is, beyond only a wall, but a hallway with sitting and lying area for employees attached with a green wall where the workers can grow vegetables and herbals.

The envelope which faces the order entry has showcase shelves for displaying the company's products, the other envelope was built with seats with various dimensions for suitable postures and bookshelves that employees can store references and documents (*Experimental Office: No Chairs, No Desks*, n.d.).

### **Determining material**

The use of timber in this project allowed for multiple advantages in terms of ease of construction, sustainability, sound absorption and aesthetics (*Wood Fibre Room Lining Board*, n.d.). By using a lightweight timber construction, the pavilion will be able to be pre-fabricated off-site and easily transported as there are many elements. On-site installation will also be faster with this use of timber.

## **Discussion**

The final form on the top view looks modernist with simple volume, the envelope, however, reflects the deconstructivism styles. The new separator was established with the order

## ARCHITECTURAL DESIGN I REPORT

of randomness and this became the basis for designing external and internal appearance. Lines, random compositions of shapes and angles, although not expressed in dynamic volumes, but were employed and organized horizontally to introduce a relaxing, indoor pavilion. The architectural language was consistent on both envelop and supporting structure that enhances the load-bearing system.

# ARCHITECTURAL DESIGN I REPORT

## References

- Ashkanasy, N. M., Ashton-James, C. E., & Jordan, P. J. (2003). Performance Impacts of Appraisal and Coping With Stress in Workplace Settings: the Role of Affect and Emotional Intelligence. In *Research in Occupational Stress and Well Being* (Vol. 3).  
[https://doi.org/10.1016/S1479-3555\(03\)03001-4](https://doi.org/10.1016/S1479-3555(03)03001-4)
- Denari Project*. (n.d.). [http://cs.roboticbuilding.eu/pdf/1\\_Denari\\_Project.pdf](http://cs.roboticbuilding.eu/pdf/1_Denari_Project.pdf)
- Experimental Office: No Chairs, No Desks*. (n.d.).  
<https://nextnature.net/story/2015/experimental-office-no-chairs-no-desks>
- Wood Fibre Room Lining Board*. (n.d.). <https://materials.ads.org.uk/wood-fibre-room-lining-board/>

Appendices

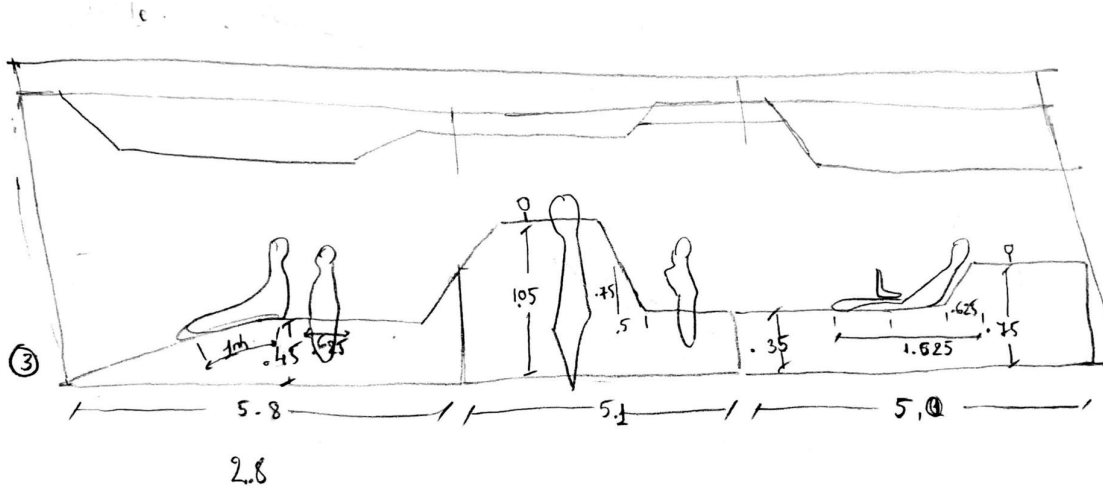

*Function sketch*

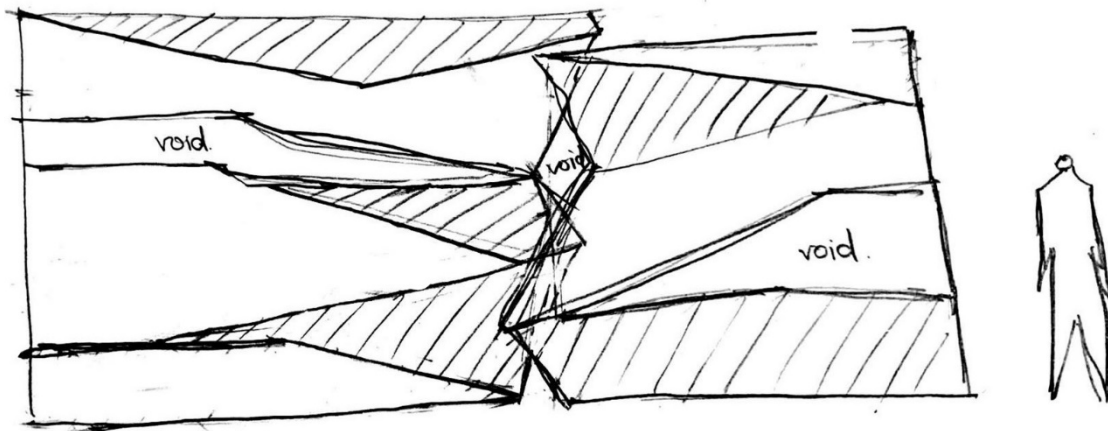

*Initial envelop sketch*

ARCHITECTURAL DESIGN I REPORT

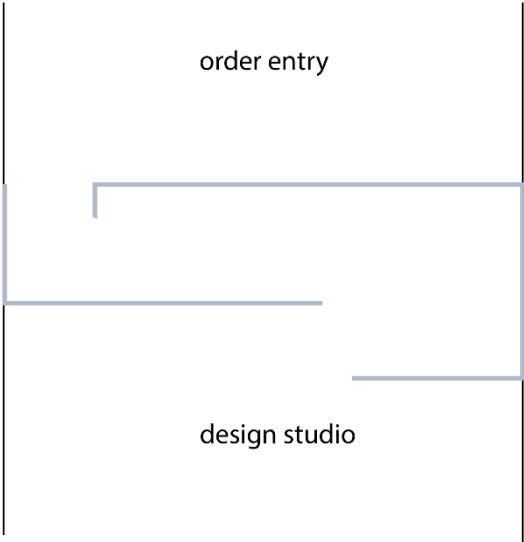

*Initial floor plan sketch*

# ARCHITECTURAL DESIGN I REPORT

## Completed design

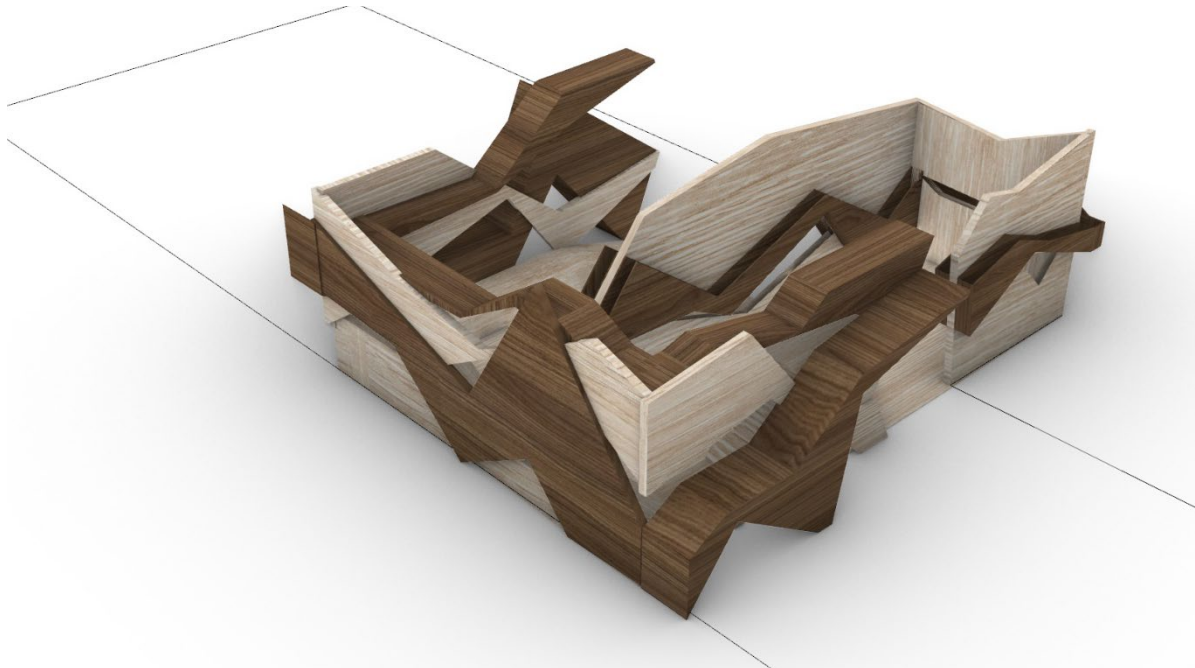
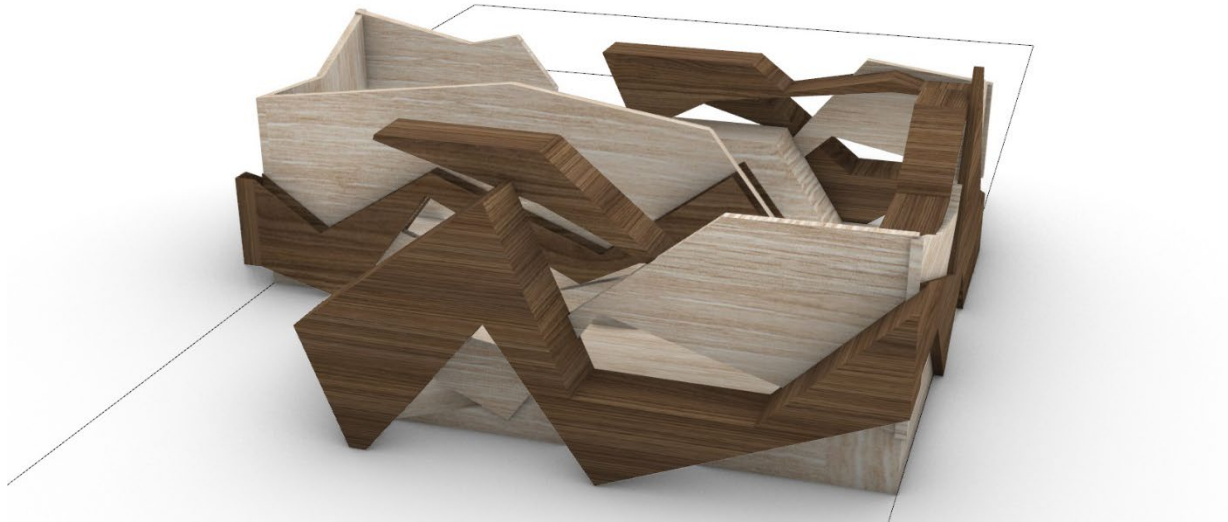

*Perspective view*





*The green wall*

ARCHITECTURAL DESIGN I REPORT



*Interior front view*



*Interior left view*

ARCHITECTURAL DESIGN I REPORT



*Interior back view*



*Exterior back view*

ARCHITECTURAL DESIGN I REPORT

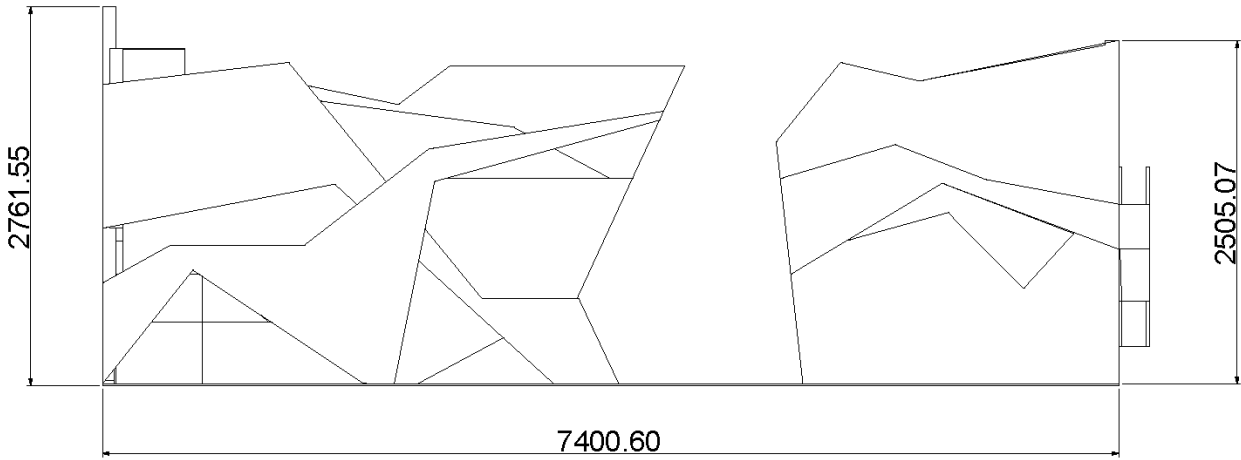
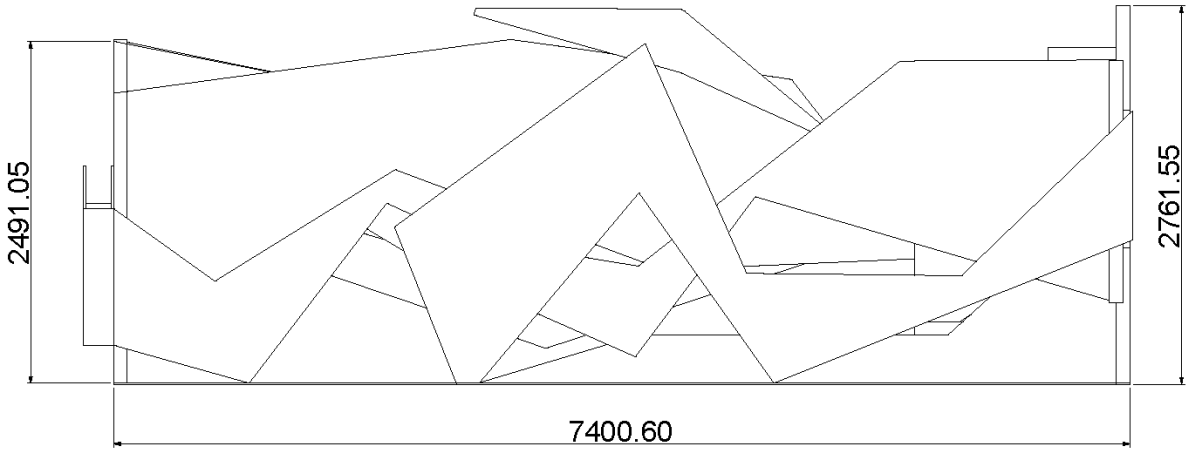

*Back view – Front view*

ARCHITECTURAL DESIGN I REPORT

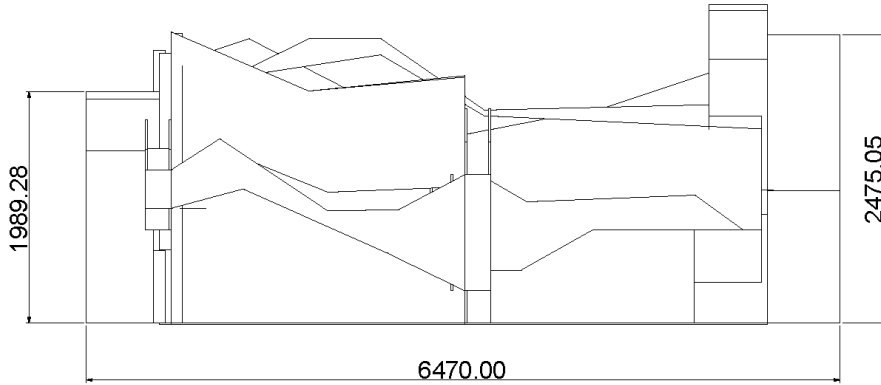
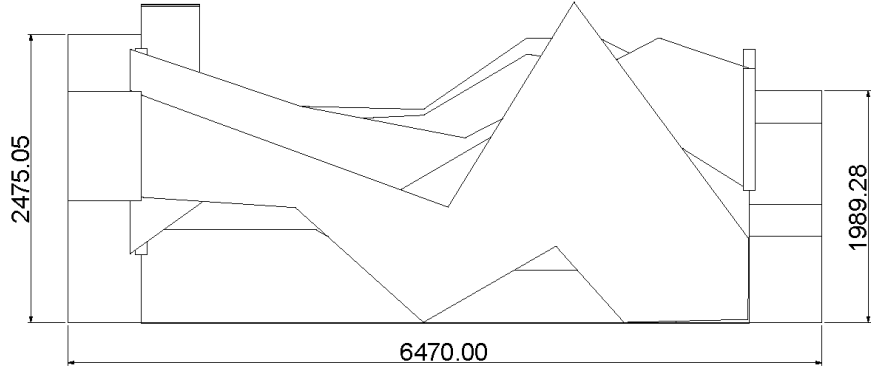

*Left view - Right view*

ARCHITECTURAL DESIGN I REPORT

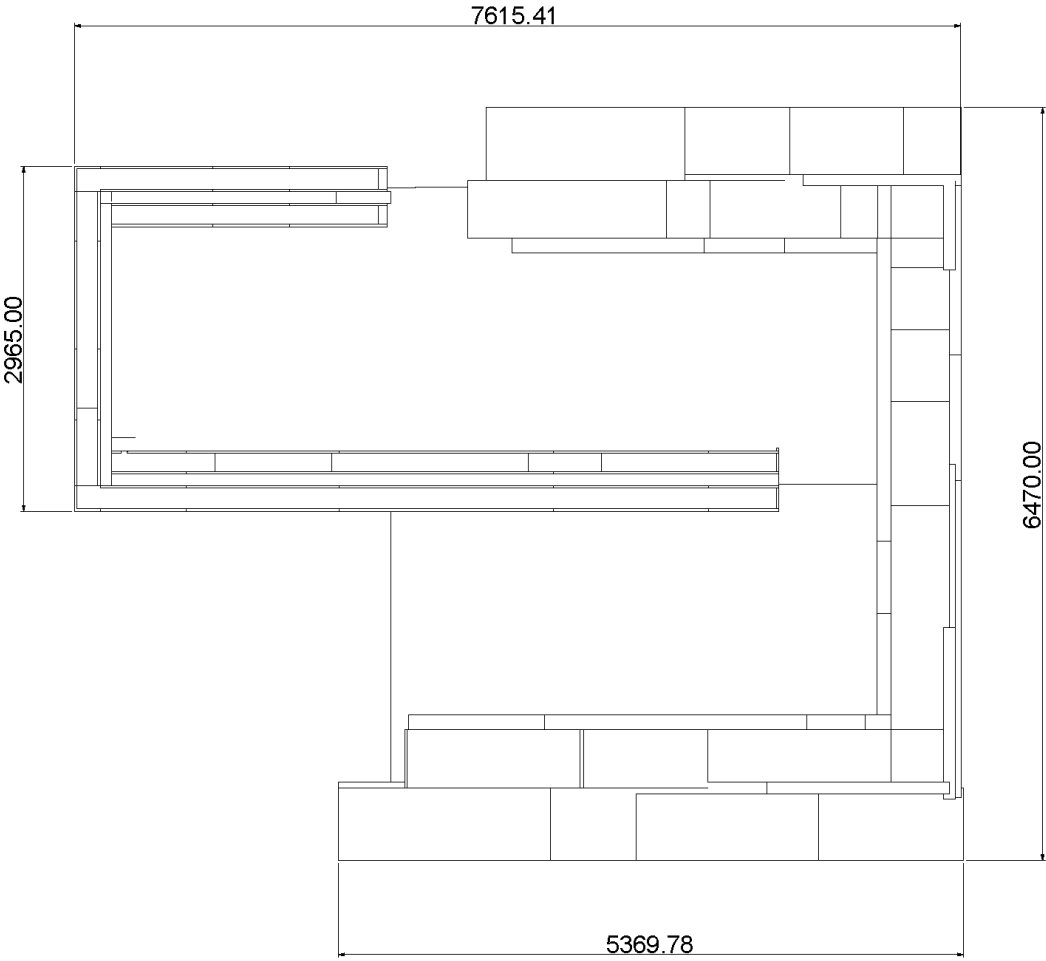

*Top view*